

# GW3010

## Power Line Communication(PLC) Modem SoC

### Description

The GW3010 is a comprehensive system-on-chip (SoC) solution that integrates all the necessary components of a power line communication (PLC) modem into a single chip. It includes a PLC modem with AFE (Analog Front End), PHY (Physical Layer), MAC (Media Access Control), and upper layers up to IPv6. With its advanced OFDM line coding and proprietary algorithms, the modem supports multi-mode modulation, ensuring reliable data transmission over power line networks. This highly integrated chip fulfills all the silicon requirements for a PLC modem, offering a compact and efficient solution.

The GW3010 supports multiple implementations, including ITU-T G.9903 (G3-PLC), ITU-T G.9904 (PRIME), IEEE P1901.2, and IEC 61334 (S-FSK). It integrates a microcontroller with internal SRAM and Flash memory. Additionally, it provides SPI, I2C, and UART interfaces, along with standard features like timers, GPIO, and interrupt capabilities.

### Features

- Complete single chip multi-mode PLC modem solution supporting OFDM Modulation.
- Integration of AFE (Analog Front End), PHY (Physical Layer), MAC (Media Access Control), and Upper layers.
- 32-bit RISC microcontroller integration with integrated SRAM and Flash memory.
- Compliant with frequency bands: CENELEC A, B, C, D, FCC, and ARIB.
- Standard and Semtech-Proprietary High-Performance Forward Error Correction (FEC)
- Integrated hardware AES Engine encryption/decryption accelerator.
- User-configured start and end operating frequency.
- Carrier Sense Multiple Access/Collision Avoidance (CSMA/CA) channel access.
- Automatic Repeat Request (ARQ) for enhanced error detection and improved data reliability.

- Support for SPI, I2C, and UART interfaces.
- OTW (Over The Wire) field upgrades.
- Industrial temperature operating range (-40°C to +85°C).

### Physical Characteristics

- Operating voltages
  - Analog core voltage: 3.3V
  - Digital core voltage: 1.2V
  - I/O voltage: 3.3V
  - OTP programming voltage: 2.5V
- Operating temperature: (-40°C to +85°C)
- PLC frequency of operation: 36 ~ 490 KHz
- Available in 64-LQFP and 56-MLPQ packages

### Typical Applications

- Smart grid
- Home automation
- Building automation
- Industrial automation
- Internet of things (IoT)
- Street lighting

### Basic Application Diagram

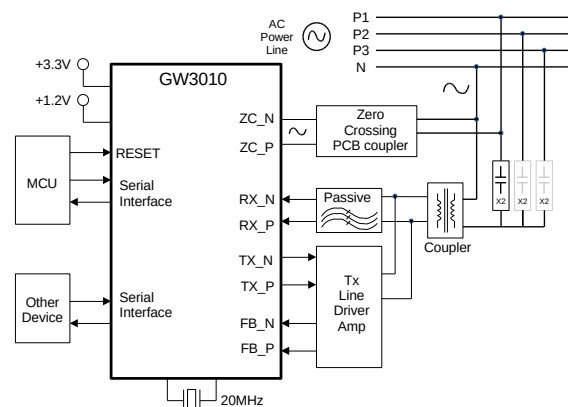

## Block Diagram

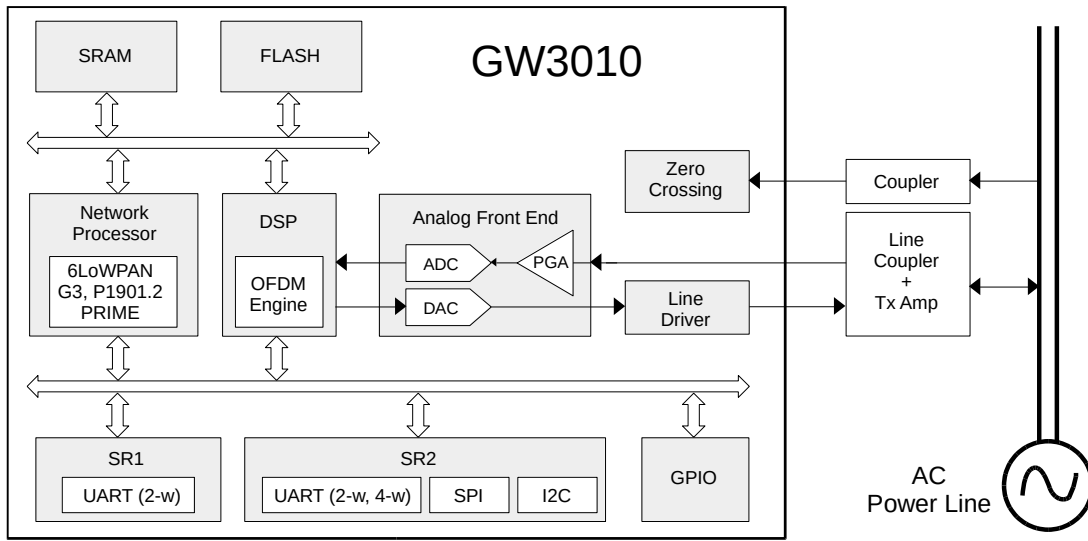
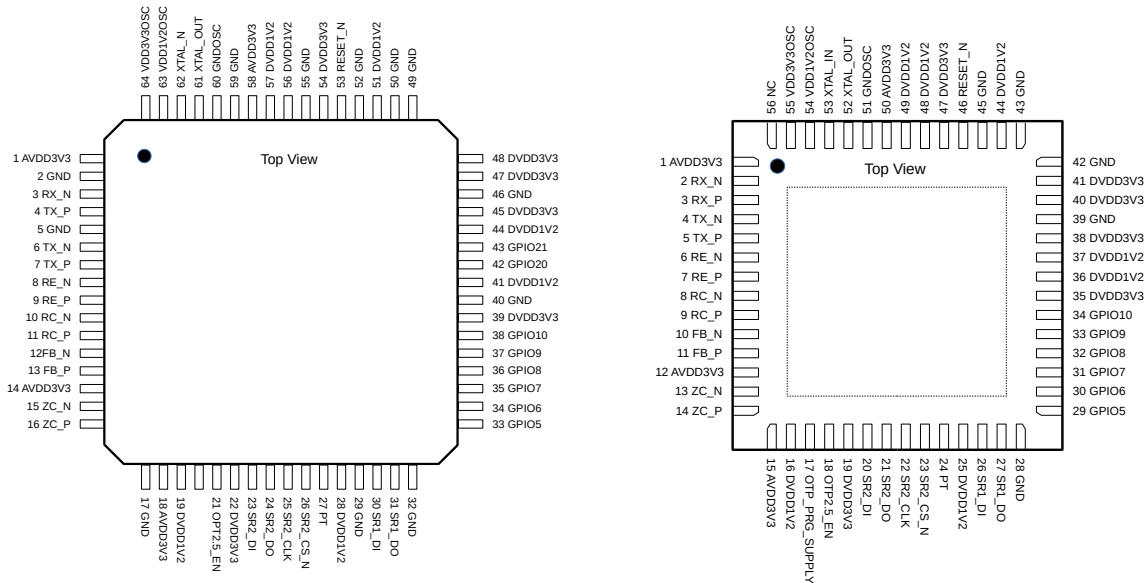

Figure 1 Functional Block Diagram of the GW3010

## Package Information



## Ordering Information

Device name	Package	Remark
GW3010_L64	64LQFP, 10x10	LQFP, Industrial
GW3010_M56	56MLPQ, 8x8	MLPQ, Industrial

## Notice

1. The descriptions of circuits, software, and other related information in this document are solely meant to demonstrate how semiconductor products operate and provide examples of their applications. You hold complete responsibility for incorporating or using the circuits, software, and information in designing your own product or system.
2. Gwanak Analog takes no responsibility for any losses or damages suffered by you or third parties resulting from the utilization of these circuits, software, or information.
3. Gwanak Analog explicitly disclaims any responsibility or liability for infringement or any other claims related to patents, copyrights, or other intellectual property rights of third parties, resulting from the use of Gwanak Analog products or technical information described in this document. This includes, but is not limited to, product data, drawings, charts, programs, algorithms, and application examples.
4. This document does not grant any form of license, whether explicit, implicit, or otherwise, under any patents, copyrights, or other intellectual property rights owned by Gwanak Analog or any other party.
5. It is your responsibility to identify and obtain any necessary licenses from third parties for the legal import, export, manufacturing, sales, use, distribution, or any other actions involving products that incorporate Gwanak Analog products, if such licenses are required.
6. You are prohibited from making any changes, modifications, copies, or reverse engineering of Gwanak Analog products, whether partially or entirely. Gwanak Analog takes no responsibility for any losses or damages suffered by you or third parties resulting from such actions of alteration, modification, copying, or reverse engineering.
7. No semiconductor product can guarantee absolute security. Despite any security measures or features incorporated into Gwanak Analog hardware or software products, Gwanak Analog holds no liability for any vulnerabilities or security breaches, including unauthorized access or usage of Gwanak Analog products or systems utilizing them. Gwanak Analog does not provide assurance or guarantee that Gwanak Analog products or systems created with them will be immune to issues like corruption, attacks, viruses, interference, hacking, data loss or theft, or other security intrusions. Gwanak Analog disclaims all responsibility and liability associated with vulnerability issues. Additionally, to the extent permitted by applicable law, Gwanak Analog disclaims all warranties, whether expressed or implied, regarding this document and any related software or hardware, including but not limited to warranties of merchantability or fitness for a particular purpose.
8. While Gwanak Analog strives to enhance the quality and reliability of its products, semiconductor products possess inherent characteristics, such as a certain failure rate and potential malfunctions under specific usage conditions. Unless explicitly specified as high-reliability products or intended for harsh environments in Gwanak Analog data sheets or other official documents, Gwanak Analog products do not incorporate radiation-resistant design. It is your responsibility to implement safety precautions to mitigate the risk of bodily harm, injuries, damage, or public hazards resulting from failures or malfunctions of Gwanak Analog products. These safety measures may include hardware and software safety design, such as redundancy, fire control, malfunction prevention, appropriate measures to address aging degradation, or other suitable actions. Since evaluating microcomputer software independently is challenging and impractical, you are accountable for assessing the safety of the final products or systems manufactured by you.
9. For specific information regarding environmental concerns related to Gwanak Analog products, kindly get in touch with a Gwanak Analog sales office. It is your responsibility to conduct a thorough investigation and ensure compliance with relevant laws and regulations pertaining to the usage or inclusion of controlled substances, including but not limited to the EU RoHS Directive. Gwanak Analog takes no responsibility for any damages or losses incurred due to your failure to comply with applicable laws and regulations.
10. Gwanak Analog products and technologies must not be utilized or included in any products or systems that are prohibited by domestic or foreign laws or regulations. You are required to adhere to export control laws and regulations imposed by governments of countries that assert jurisdiction over the parties involved or the transactions taking place.
11. The buyer, distributor, or any party involved in the distribution, sale, or transfer of Gwanak Analog products to a third party is responsible for informing the third party in advance about the contents and conditions specified in this document.
12. The content of this document cannot be reproduced, copied, or duplicated, either fully or partially, without obtaining prior written consent from Gwanak Analog.
13. If you have any inquiries about the information provided in this document or Gwanak Analog products, please reach out to a Gwanak Analog sales office for assistance.

## Corporate Headquarters

Gwanak Analog Co., Ltd.,  
5F, Seoul National University Research Park,  
1 Gwanak-ro, Gwanak-gu, Seoul, 08826, Korea

## Contact Information

For further information on a product, technology, the most up-to-date version of a document, or your nearest sales office, please visit:  
[www.gwanakanalog.com](http://www.gwanakanalog.com)

## Trademarks

Gwanak Analog and Gwanak Analog logo are trademarks of Gwanak Analog Company. All trademarks and registered trademarks are the property of their respective owners.